

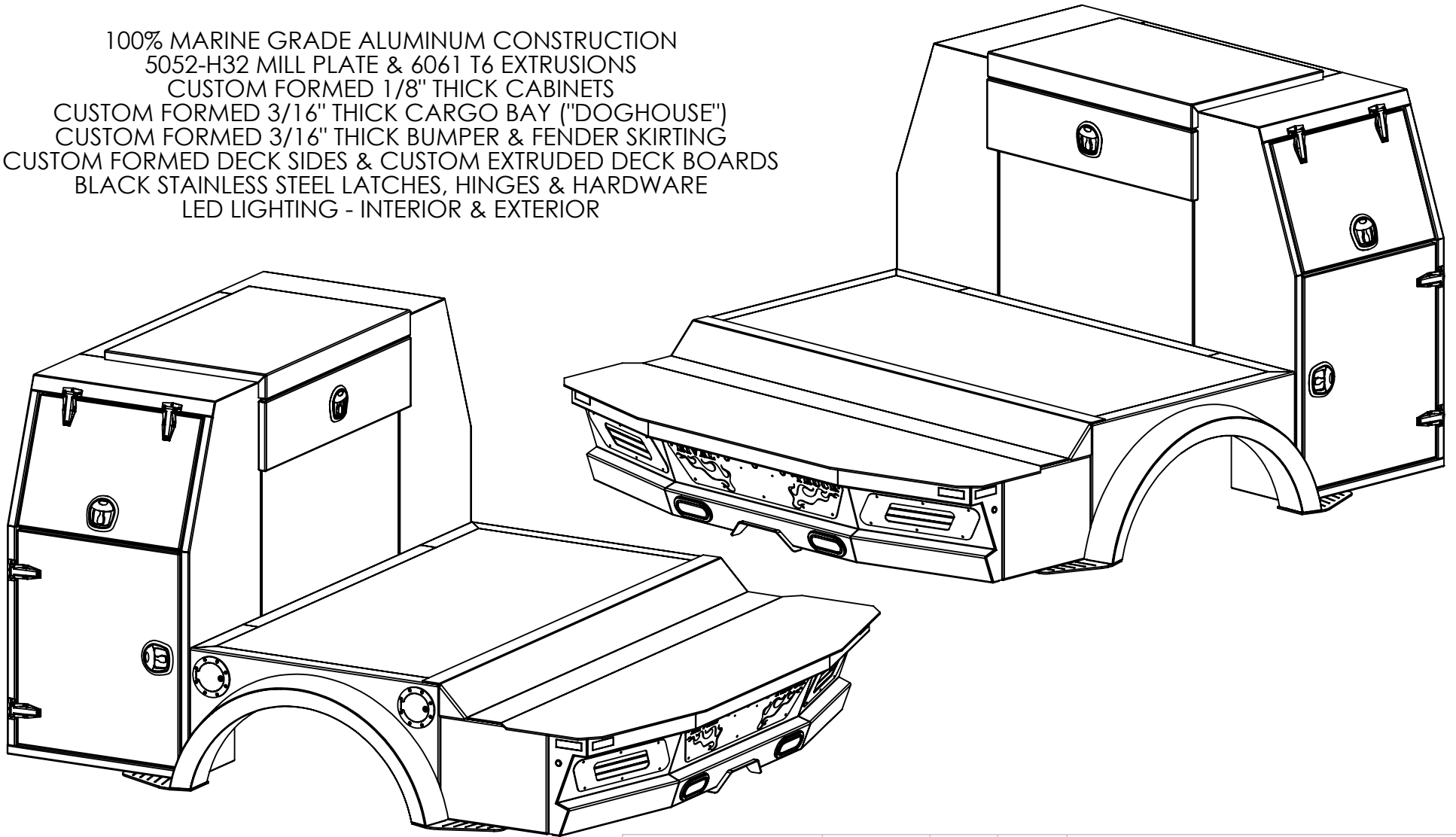

100% MARINE GRADE ALUMINUM CONSTRUCTION  
 5052-H32 MILL PLATE & 6061 T6 EXTRUSIONS  
 CUSTOM FORMED 1/8" THICK CABINETS  
 CUSTOM FORMED 3/16" THICK CARGO BAY ("DOGHOUSE")  
 CUSTOM FORMED 3/16" THICK BUMPER & FENDER SKIRTING  
 CUSTOM FORMED DECK SIDES & CUSTOM EXTRUDED DECK BOARDS  
 BLACK STAINLESS STEEL LATCHES, HINGES & HARDWARE  
 LED LIGHTING - INTERIOR & EXTERIOR



**PROPRIETARY AND CONFIDENTIAL**  
 THE INFORMATION CONTAINED IN THIS DRAWING IS THE SOLE PROPERTY OF EXPRESS CUSTOM MFG. ANY REPRODUCTION IN PART OR AS A WHOLE WITHOUT THE WRITTEN PERMISSION OF EXPRESS CUSTOM MFG. IS PROHIBITED.

UNLESS OTHERWISE SPECIFIED:		NAME	DATE
DIMENSIONS ARE IN INCHES TOLERANCES: ± .01 FRACTIONAL ± .1 ANGULAR: MACH ± .1 BEND ± TWO PLACE DECIMAL .01 ± THREE PLACE DECIMAL .001 ±		MODEL	S 12/22/2013
INTERPRET GEOMETRIC TOLERANCING PER:		DRAWING	S 12/22/2013
MATERIAL ALUMINUM		REVISION	
FINISH CLEAN		MFG APPR.	
DO NOT SCALE DRAWING		Q.A.	
QUANTITY: X1			

EXPRESS CUSTOM MFG.		
TITLE: <b>RIVAL II PALADIN II 56</b>		
SIZE <b>A</b>	DWG.# R-II PALADIN II 56	REV
SCALE: N/A	WEIGHT:	SHEET 1 OF 6

5

4

3

2

1

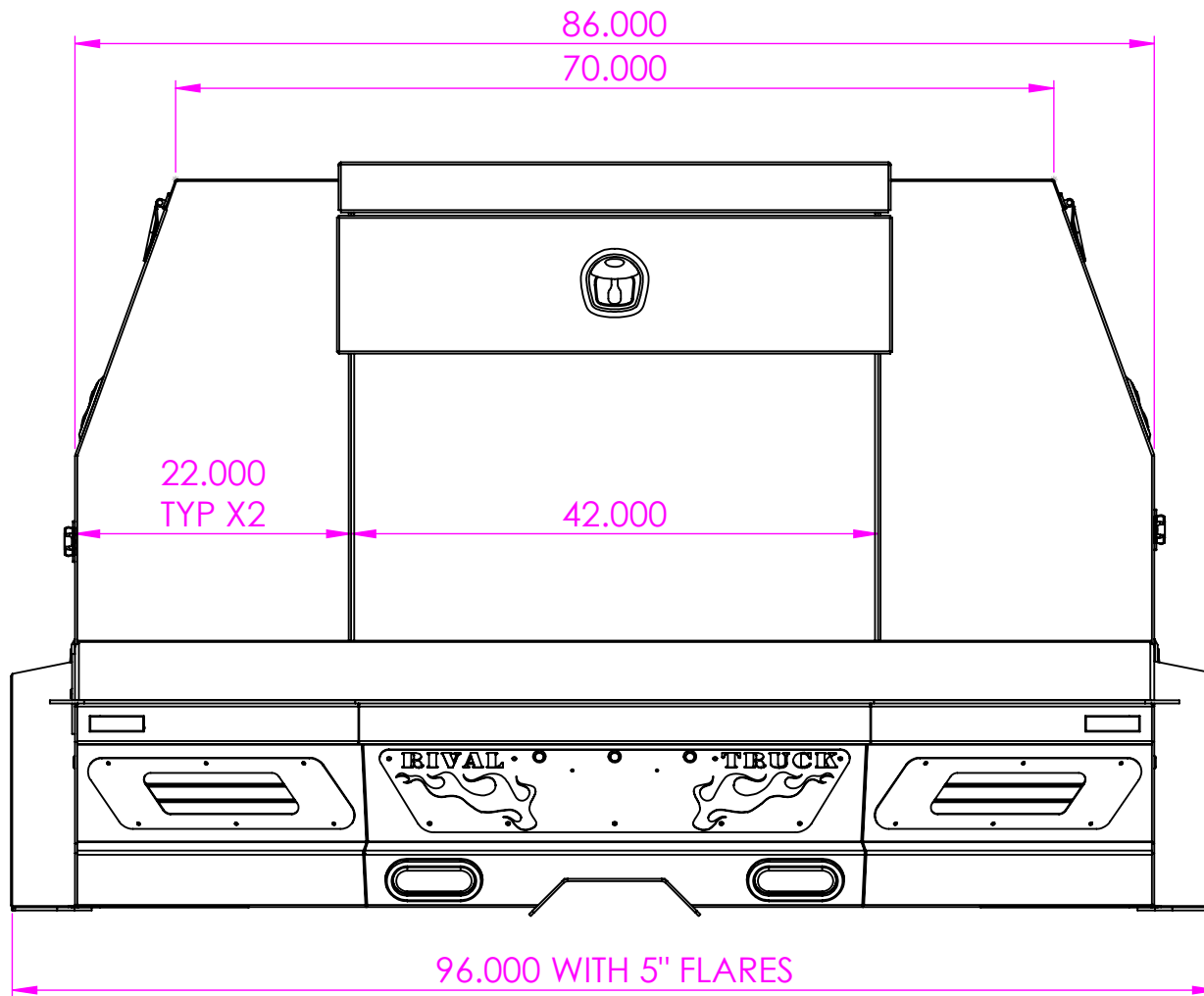

**PROPRIETARY AND CONFIDENTIAL**  
 THE INFORMATION CONTAINED IN THIS DRAWING IS THE SOLE PROPERTY OF EXPRESS CUSTOM MFG. ANY REPRODUCTION IN PART OR AS A WHOLE WITHOUT THE WRITTEN PERMISSION OF EXPRESS CUSTOM MFG. IS PROHIBITED.

UNLESS OTHERWISE SPECIFIED:		NAME	DATE
DIMENSIONS ARE IN INCHES TOLERANCES: ± .01 FRACTIONAL ± .1 ANGULAR: MACH ± .1 BEND ± TWO PLACE DECIMAL .01 ± THREE PLACE DECIMAL .001 ±		MODEL	S 12/22/2013
INTERPRET GEOMETRIC TOLERANCING PER:		DRAWING	S 12/22/2013
MATERIAL ALUMINUM		REVISION	
FINISH CLEAN		MFG APPR.	
DO NOT SCALE DRAWING		Q.A.	
QUANTITY: X1			

<b>EXPRESS CUSTOM MFG.</b>		
TITLE: <b>RIVAL II PALADIN II 56</b>		
SIZE <b>A</b>	DWG.# <b>R-II PALADIN II 56</b>	REV
SCALE: N/A	WEIGHT:	SHEET 2 OF 6

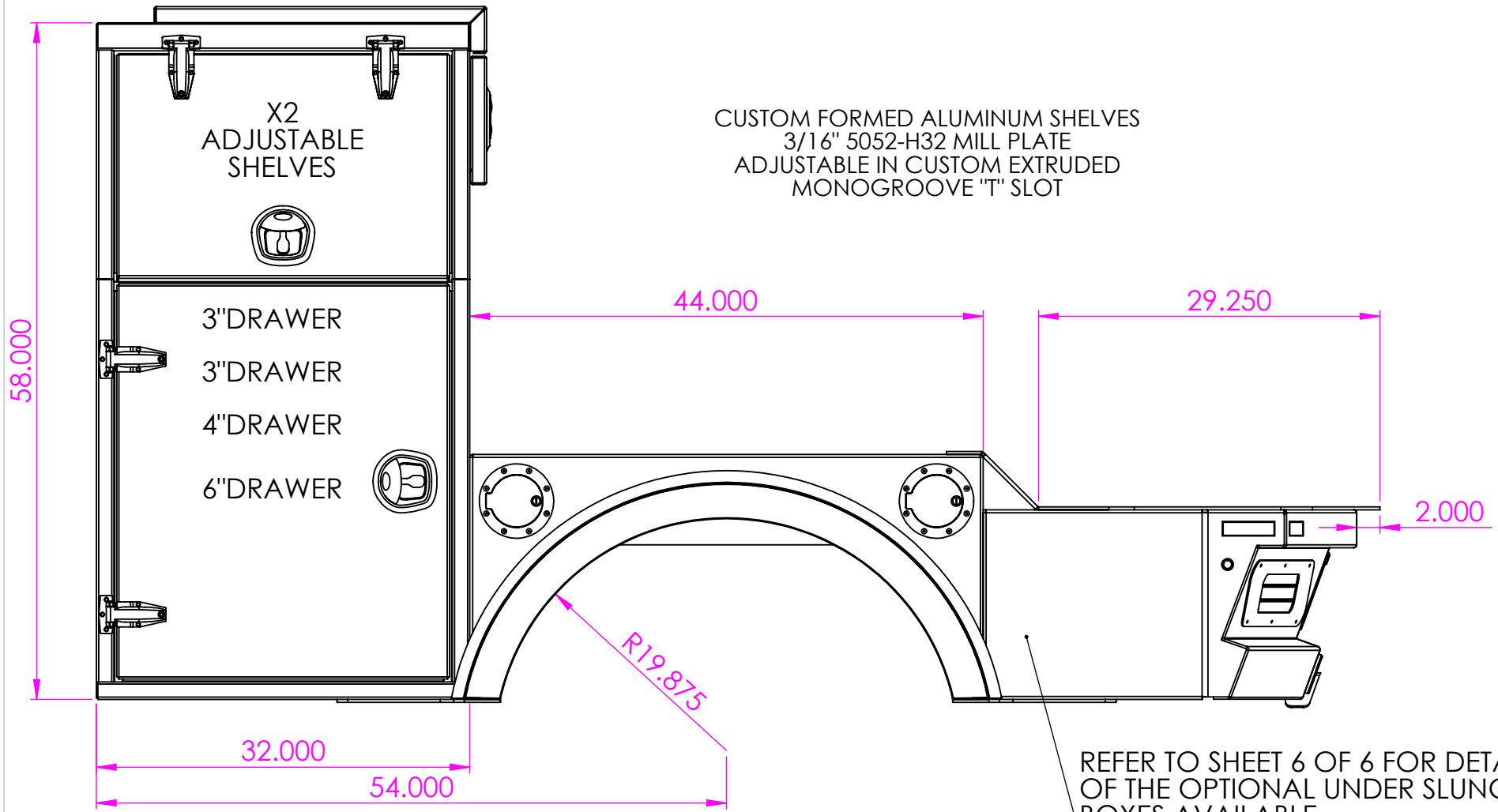

REFER TO SHEET 6 OF 6 FOR DETAILS OF THE OPTIONAL UNDER SLUNG BOXES AVAILABLE

PREMIUM ALUMINUM TOOL DRAWERS  
WIDTH: 22.6" DEPTH: 16.2" OVERALL HEIGHT: 18.3"  
.100" THICK 5052-H32 MILL PLATE  
250LB 100% EXTENSION DRAWER SLIDES  
SLAM LATCHES W/LOCKING "T" HANDLES

**PROPRIETARY AND CONFIDENTIAL**  
THE INFORMATION CONTAINED IN THIS DRAWING IS THE SOLE PROPERTY OF EXPRESS CUSTOM MFG. ANY REPRODUCTION IN PART OR AS A WHOLE WITHOUT THE WRITTEN PERMISSION OF EXPRESS CUSTOM MFG. IS PROHIBITED.

UNLESS OTHERWISE SPECIFIED:		NAME	DATE	<b>EXPRESS CUSTOM MFG.</b>	
DIMENSIONS ARE IN INCHES TOLERANCES: ± .01 FRACTIONAL ± .1 ANGULAR: MACH ± .1 BEND ± TWO PLACE DECIMAL .01 ± THREE PLACE DECIMAL .001 ±		MODEL	S 12/22/2013		TITLE: <b>RIVAL II PALADIN II 56</b>
INTERPRET GEOMETRIC TOLERANCING PER:		DRAWING	S 12/22/2013		
MATERIAL ALUMINUM		REVISION			SIZE DWG.# REV <b>A R-II PALADIN II 56</b>
FINISH CLEAN		MFG APPR.			
DO NOT SCALE DRAWING		Q.A.		SCALE: N/A WEIGHT: SHEET 3 OF 6	



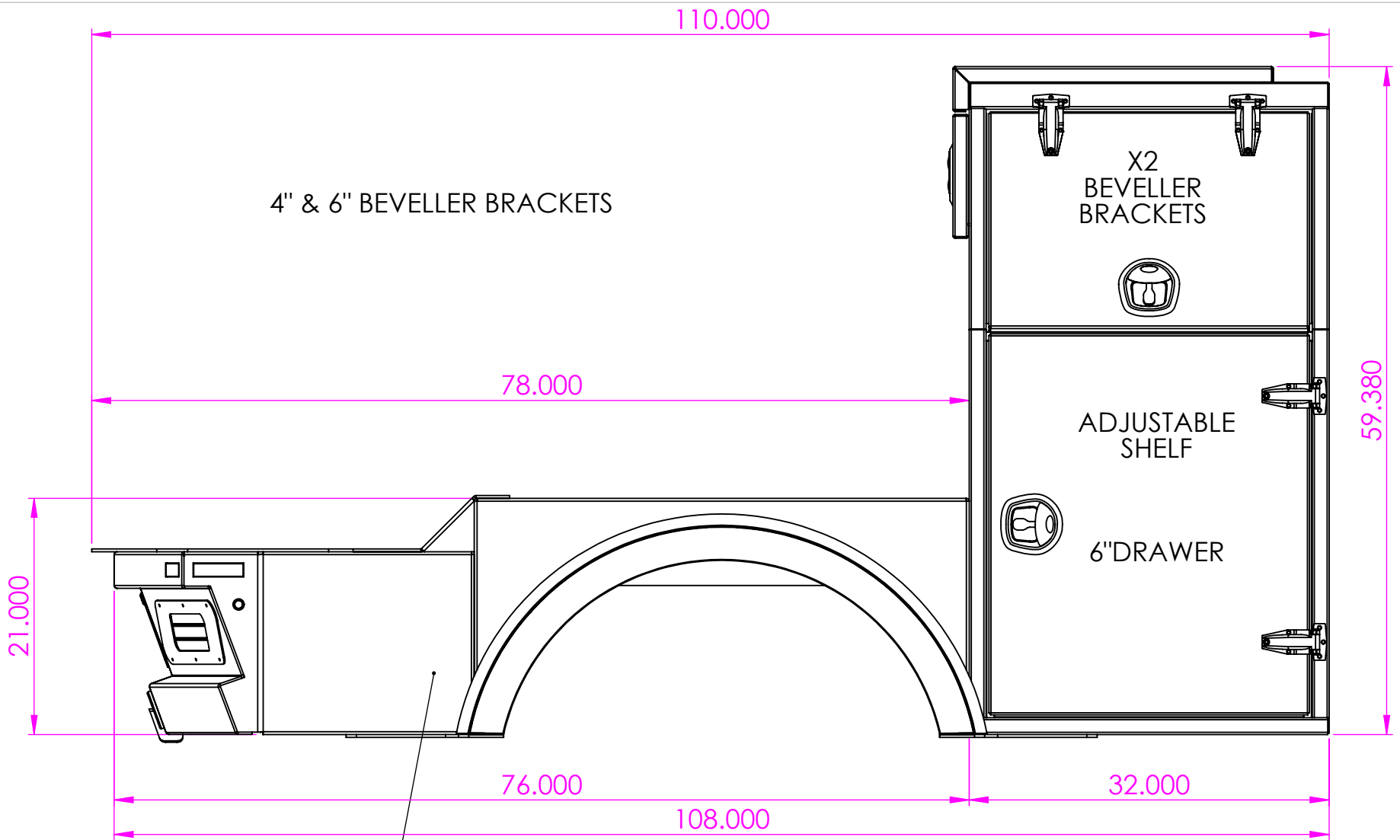

REFER TO SHEET 6 OF 6 FOR DETAILS OF THE OPTIONAL UNDER SLUNG BOXES AVAILABLE

**PROPRIETARY AND CONFIDENTIAL**  
 THE INFORMATION CONTAINED IN THIS DRAWING IS THE SOLE PROPERTY OF EXPRESS CUSTOM MFG. ANY REPRODUCTION IN PART OR AS A WHOLE WITHOUT THE WRITTEN PERMISSION OF EXPRESS CUSTOM MFG. IS PROHIBITED.

UNLESS OTHERWISE SPECIFIED:		NAME	DATE
DIMENSIONS ARE IN INCHES TOLERANCES: ± .01 FRACTIONAL ± .1 ANGULAR: MACH ± .1 BEND ± TWO PLACE DECIMAL .01 ± THREE PLACE DECIMAL .001 ±		MODEL	S 12/22/2013
INTERPRET GEOMETRIC TOLERANCING PER:		DRAWING	S 12/22/2013
MATERIAL ALUMINUM		REVISION	
FINISH CLEAN		MFG APPR.	
DO NOT SCALE DRAWING		Q.A.	
QUANTITY: X1			

<b>EXPRESS CUSTOM MFG.</b>		
TITLE: <b>RIVAL II PALADIN II 56</b>		
SIZE <b>A</b>	DWG.# <b>R-II PALADIN II 56</b>	REV
SCALE: N/A	WEIGHT:	SHEET 4 OF 6

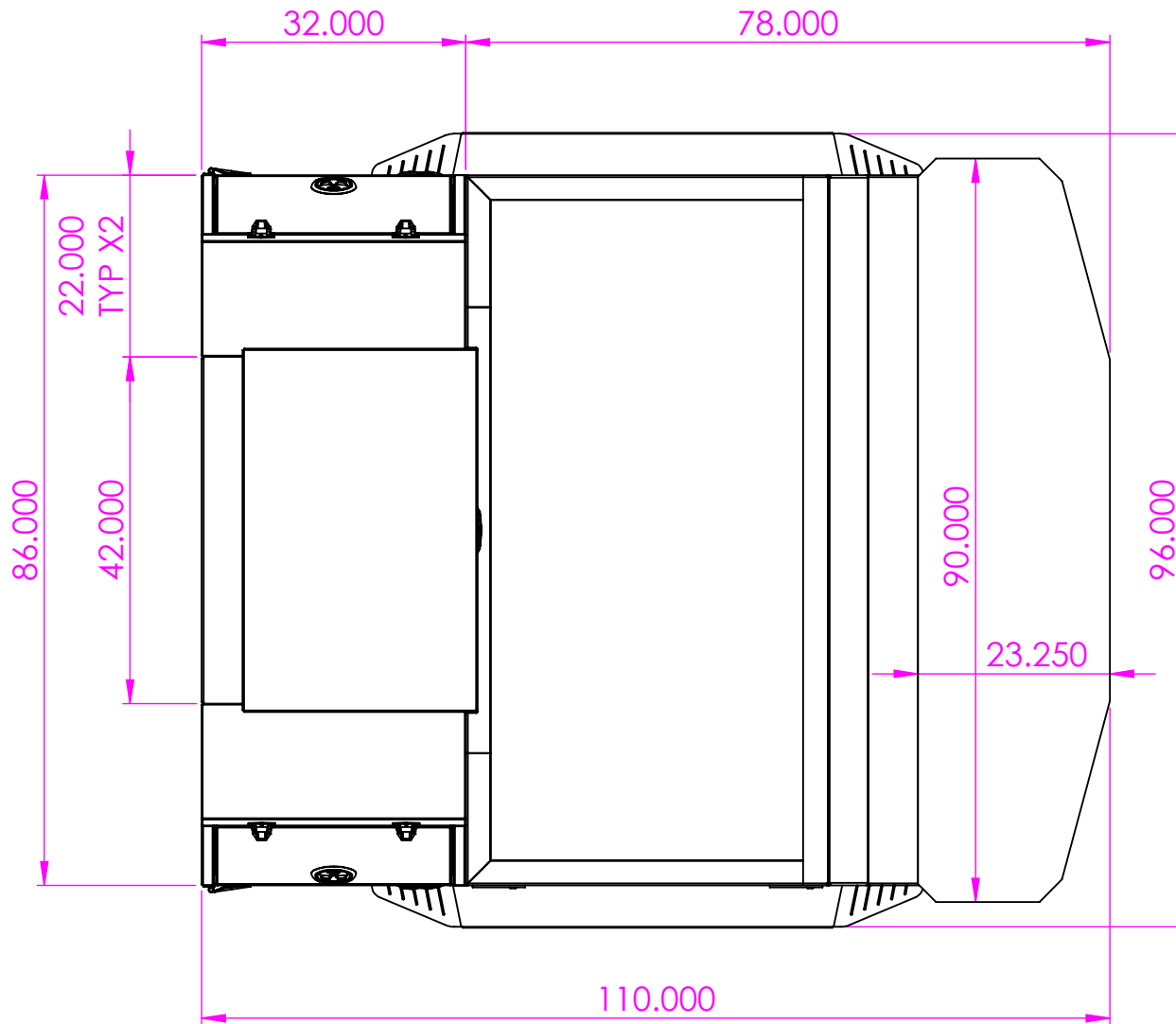

UNLESS OTHERWISE SPECIFIED:		NAME	DATE
DIMENSIONS ARE IN INCHES TOLERANCES: ± .01 FRACTIONAL ±.1 ANGULAR: MACH ±.1 BEND ± TWO PLACE DECIMAL .01 ± THREE PLACE DECIMAL .001 ±  INTERPRET GEOMETRIC TOLERANCING PER:	MODEL	S	12/22/2013
	DRAWING	S	12/22/2013
	REVISION		
	MFG APPR.		
	Q.A.		
MATERIAL	ALUMINUM		
FINISH	CLEAN		
DO NOT SCALE DRAWING		QUANTITY: X1	

<b>EXPRESS CUSTOM MFG.</b>		
<b>TITLE:</b> <b>RIVAL II</b> <b>PALADIN II 56</b>		
<b>SIZE</b> <b>A</b>	<b>DWG.#</b> <b>R-II PALADIN II 56</b>	<b>REV</b>
<b>SCALE:</b> N/A	<b>WEIGHT:</b>	<b>SHEET 5 OF 6</b>

**PROPRIETARY AND CONFIDENTIAL**  
 THE INFORMATION CONTAINED IN THIS DRAWING IS THE SOLE PROPERTY OF EXPRESS CUSTOM MFG. ANY REPRODUCTION IN PART OR AS A WHOLE WITHOUT THE WRITTEN PERMISSION OF EXPRESS CUSTOM MFG. IS PROHIBITED.

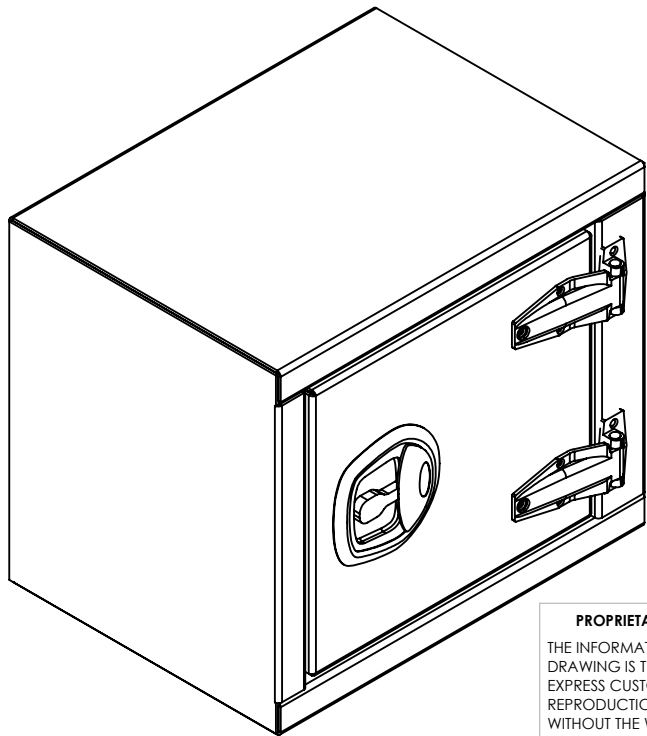
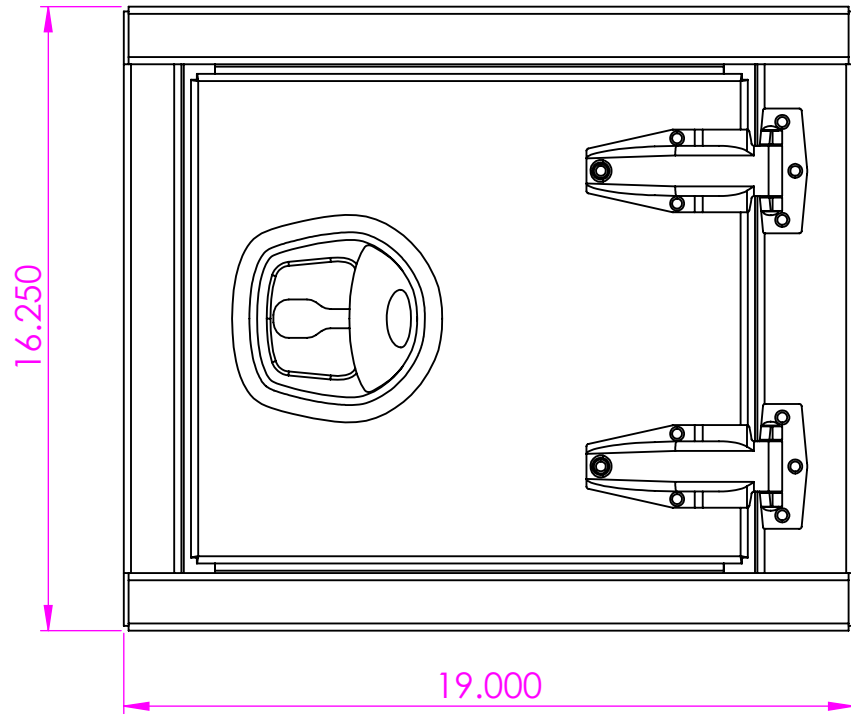
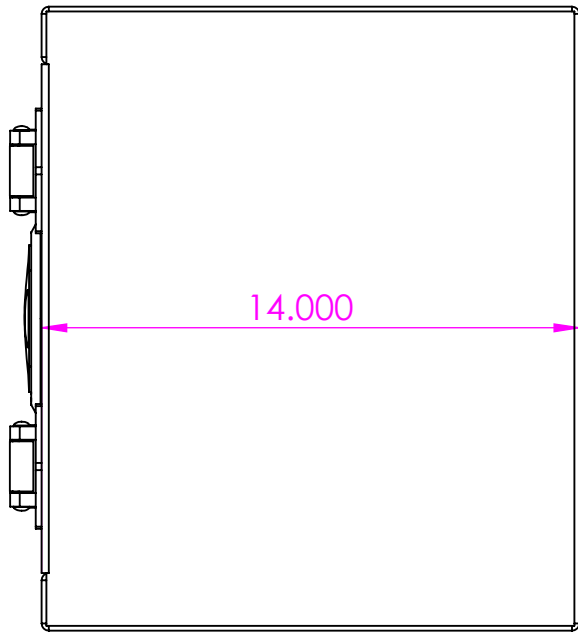

**PROPRIETARY AND CONFIDENTIAL**  
 THE INFORMATION CONTAINED IN THIS DRAWING IS THE SOLE PROPERTY OF EXPRESS CUSTOM MFG. ANY REPRODUCTION IN PART OR AS A WHOLE WITHOUT THE WRITTEN PERMISSION OF EXPRESS CUSTOM MFG. IS PROHIBITED.

UNLESS OTHERWISE SPECIFIED:		NAME	DATE	<b>EXPRESS CUSTOM MFG.</b>	
DIMENSIONS ARE IN INCHES TOLERANCES: ± .01 FRACTIONAL ± .1 ANGULAR: MACH ± .1 BEND ± TWO PLACE DECIMAL .01 ± THREE PLACE DECIMAL .001 ±		MODEL	S	12/22/2013	TITLE: <b>RIVAL II PALADIN II 56</b>
INTERPRET GEOMETRIC TOLERANCING PER:		DRAWING	S	1/01/2014	
MATERIAL		REVISION			
FINISH		MFG APPR.			
DO NOT SCALE DRAWING		ALUMINUM	Q.A.		SIZE DWG.# <b>A</b> UNDER SLUNG BOX 16.25"HX14"DX19"W
		CLEAN			REV
		QUANTITY: X1	SCALE: N/A WEIGHT:		SHEET 6 OF 6